

# KIWATEK OSU-P1901 19" PANEL

## Dimensions:

457.40mm(W) x 382.10mm (D) x 54.80mm (H)(18.0" x 15.4" x 2.1")

## Motherboard Spec.

For IMB-190-E Motherboard.

## Back Panel:

Power SW . Power LED . HDD LED .  
USB 2.0 Port x 2 . USB 3.0 Port x 4 .  
Gigabit LAN x 2 . HDMI x 3 .  
Audio IN/OUT .  
DB9 x 4 .  
12V/19~24V DC in

## Drive bays:

2.5" HDD x2

## Power Input:

C7(80W)  
C4(120W)

## Construction:

Metal chassis  
Aluminum chassis  
Low Operation temperature

## RoHS Compliant

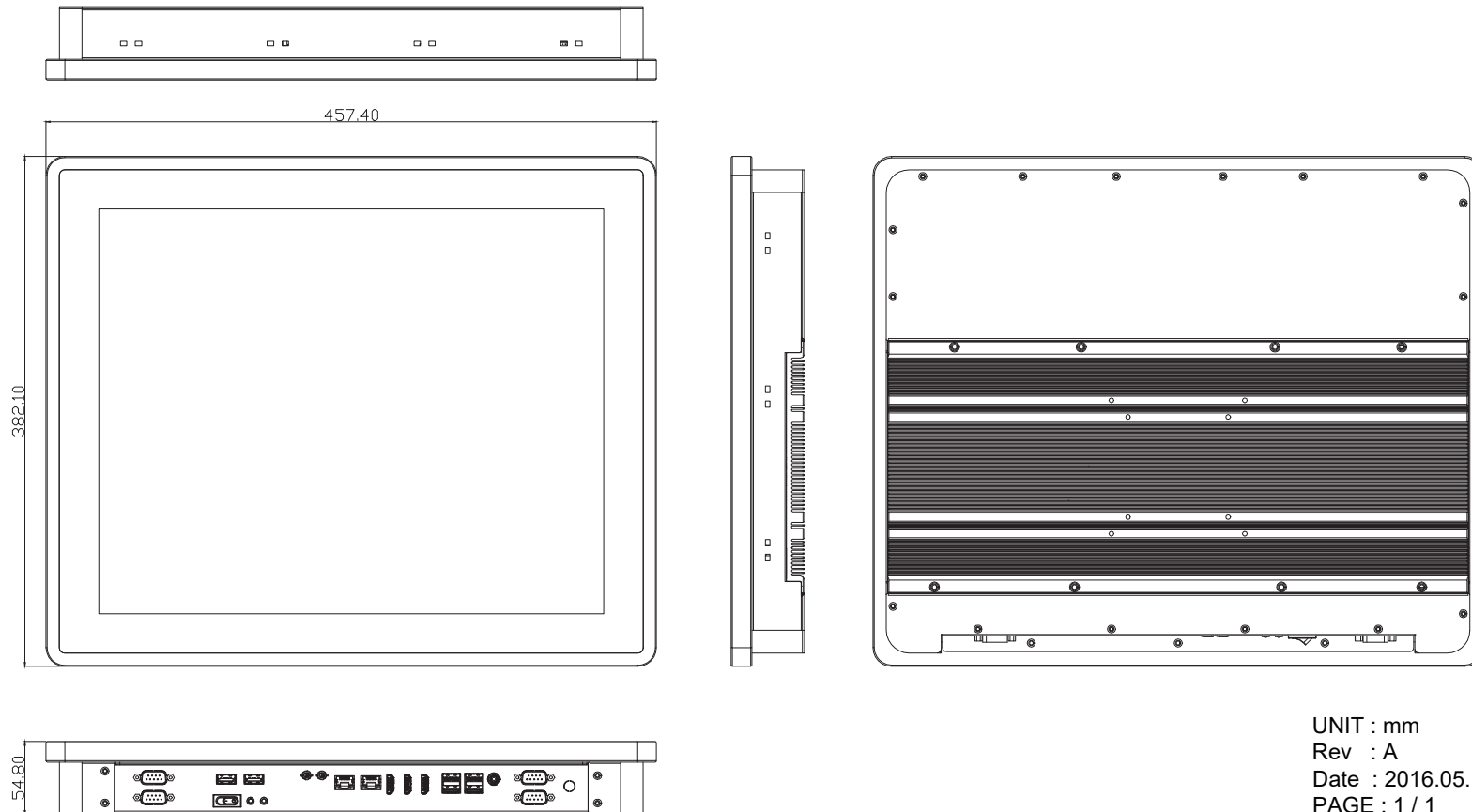
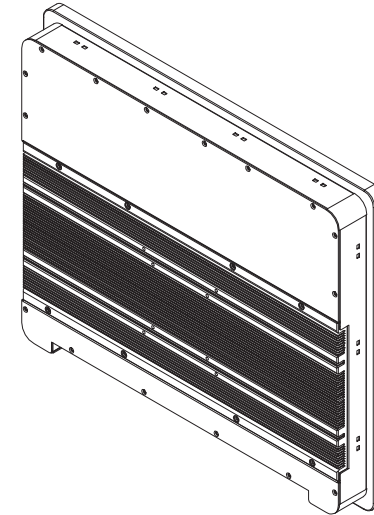
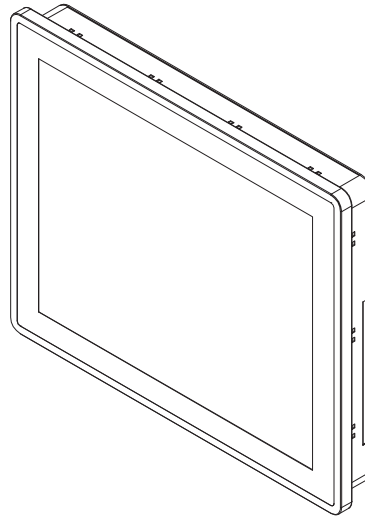

UNIT : mm  
Rev : A  
Date : 2016.05.17  
PAGE : 1 / 1